



INSTALLATION INSTRUCTIONS

Accessory
**REMOTE ENGINE
START SYSTEM**
P/N 38015-TZ3-A10

Application
2016 TLX

Publications No.
VERSION 1
Issue Date
SEP 2015

NOTE: For additional technical information, refer to the vehicle service manual.

PARTS LIST

Bracket

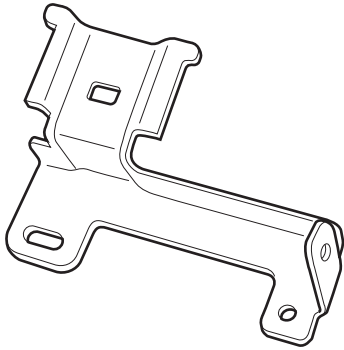

Transceiver

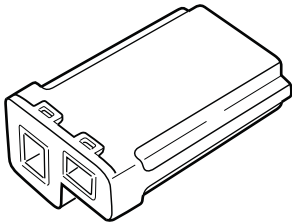

Remote (2)

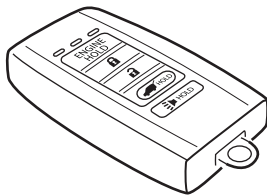

Wire tie with clip

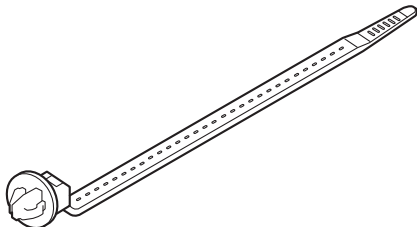

INSTALLATION

Client Information: The information in this installation instruction is intended for use only by skilled technicians who have the proper tools, equipment, and training to correctly and safely add equipment to your vehicle. These procedures should not be attempted by “do-it-yourselfers.”

1. Remove the bolt between the rear seat-back and the rear seat cushion.

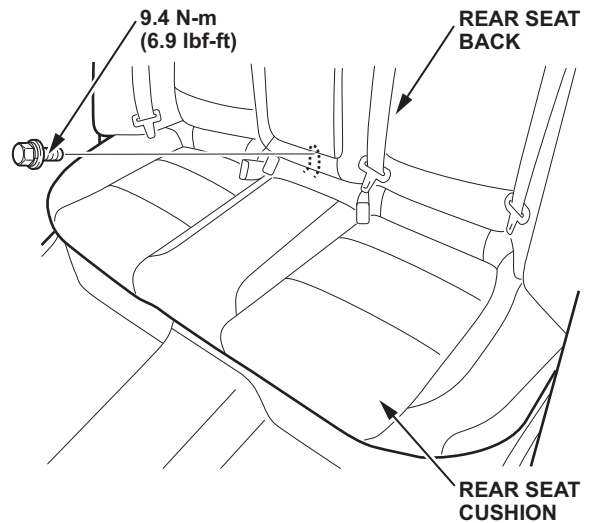

2. While pushing down on the seat cushion, pull the seat hook handles to release the hooks.

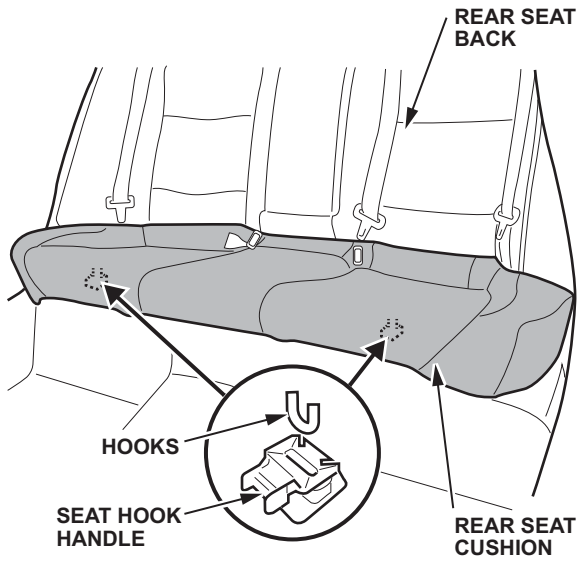

3. Remove the rear seat cushion.
4. Remove the bolt securing the side bolster. Lift up the bolster to release the hook and remove the bolster.

PASSENGER SIDE:

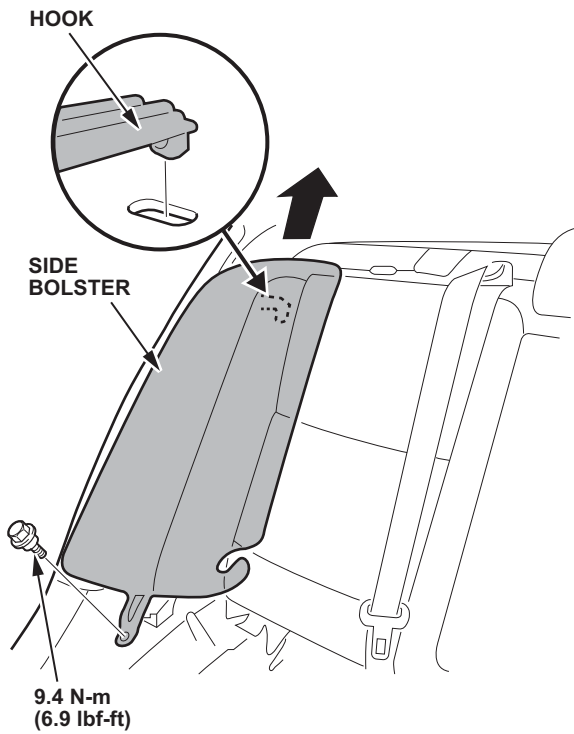

5. Remove and discard the harness wire tie.

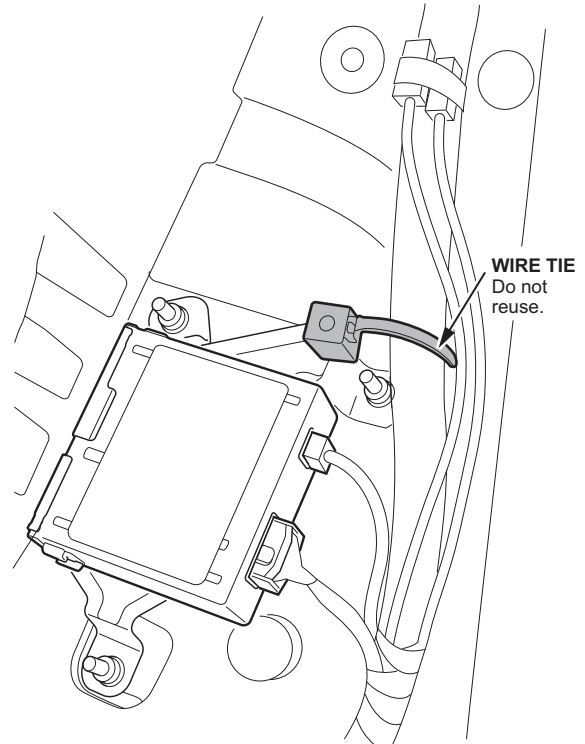

6. Remove the three XM unit bracket nuts.

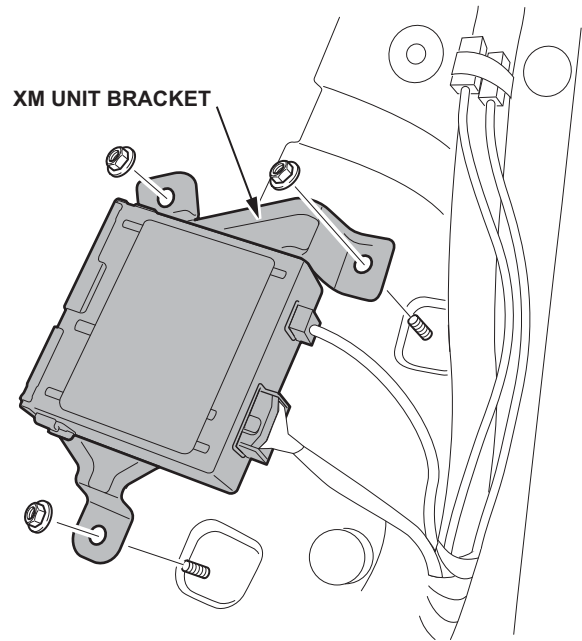

7. Slide the transceiver onto the bracket.

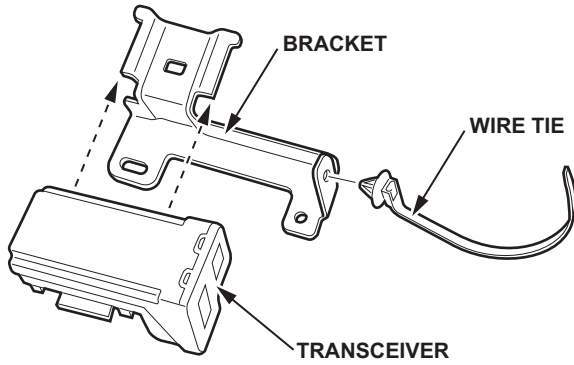

8. Connect the wire tie with clip to the bracket.
9. Lift the XM unit off the studs, and slide the transceiver bracket onto the upper two studs.

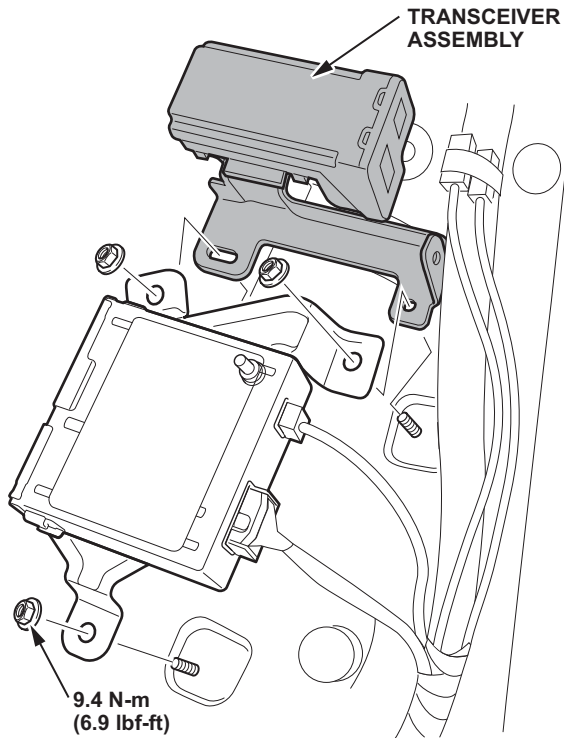

10. Reinstall the XM unit using the three nuts and torque to 9.4 N•m (6.9 lbf-ft).

11. Locate the green and black connectors blue-taped to the vehicle harness, and remove the blue tape to free the connectors.

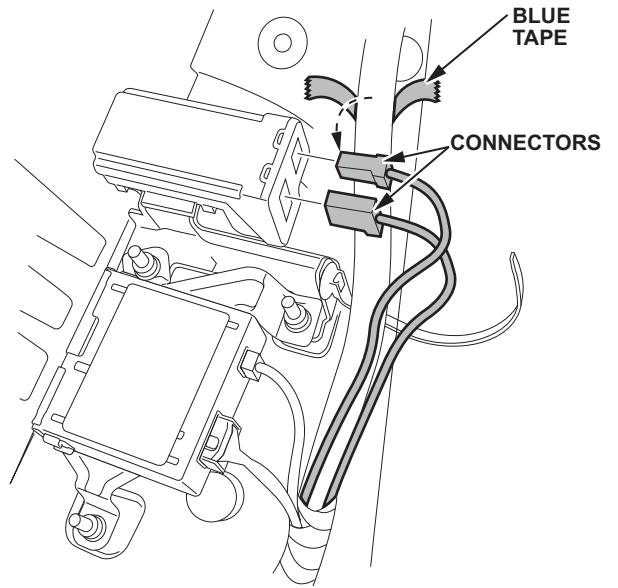

12. Connect the green and black connectors to the transceiver.
13. Secure the vehicle harness to the transceiver bracket with the wire tie.

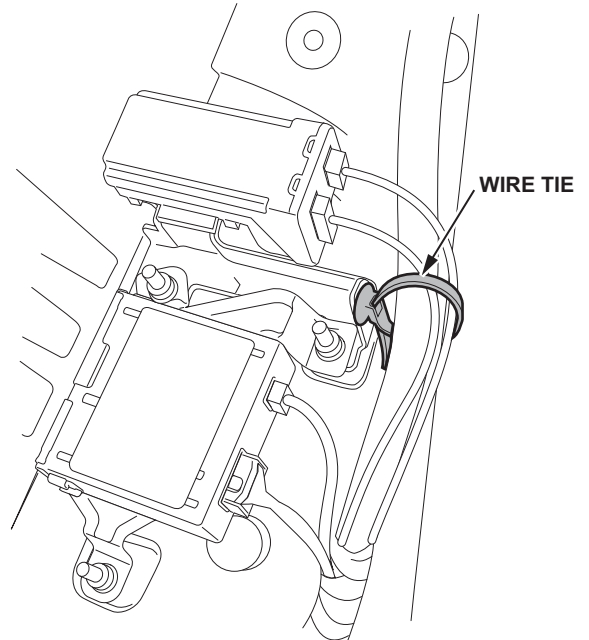

14. Reinstall all removed parts.

ENGINE REMOTE START SYSTEM REGISTRATION

NOTE: the PCM code will be required for this procedure.

1. Connect the HDS to the data link connector.
2. From the System Selection Menu, select ONE-PUSH START, then go to Registration.
3. From the Registration Menu, select KEYLESS ACCESS Remotes, then select 2-WAY KEYLESS SETUP. Change the setting to 2-WAY KEYLESS mode.
4. Go back to the KEYLESS ACCESS Remotes Registration Menu, select Add a KEYLESS ACCESS Remote, and follow the instructions on the HDS screen. Do not bring the Remote Starter remote into the vehicle until the HDS asks for the new remote.
5. Repeat step 4 for the second Remote Starter remote.
6. After registration, verify all remote-related systems work normally with all remotes.

REMOTE ENGINE START

1. Press LOCK, then press and hold ENGINE. The amber LED blinks, and the green LED stays solid for one second when the engine starts. You can repeat this once at any time within 10 minutes of the initial remote start for a 10-minute extension.
2. While remote engine start is on:
 - The climate control system can warm or cool the interior, depending on the ambient temperature.
 - The security system remains on.
 - Exterior lights and accessories remain off.
3. To start driving after you enter the vehicle, depress the brake pedal and press ENGINE/START/STOP.

STOPPING THE ENGINE

Press and hold ENGINE. The red LED stays solid for one second.

NOTE: The engine will stop if it has been running for more than 10 minutes or any door is opened without using the remote or keyless access.

For additional technical information, refer to the vehicle owner's manual.